



HEIDENHAIN



Product Information

IK 220

Interpolation and
Counter Card

March 2006

Interpolation and Counter Card

Description

The IK 220 is a counter card for linear and angular measurement with the aid of a personal computer. Two HEIDENHAIN encoders with sinusoidal current signals ($\sim 11 \mu\text{A}_{pp}$), sinusoidal voltage signals ($\sim 1 \text{V}_{pp}$), **EnDat** or **SSI interface** can be connected to the IK 220. It is inserted directly into a free PCI slot in the computer.

The IK 220 subdivides the periods of the sinusoidal encoder signals up to 4096-fold. They are called and stored either by using external latch inputs or by software.

A total of up to 8192 measured values can be stored in the IK 220 buffer and downloaded in a single block.

The position values from the two encoders are processed in the PC using programs created by the operator. To demonstrate the PC counter card's capabilities, examples of such programs and driver software for 98/NT/2000/XP are supplied with the card.

The IK 220 is ideal for applications requiring high-resolution encoder signals and rapid capture of measuring values.

Basic Circuit Diagram

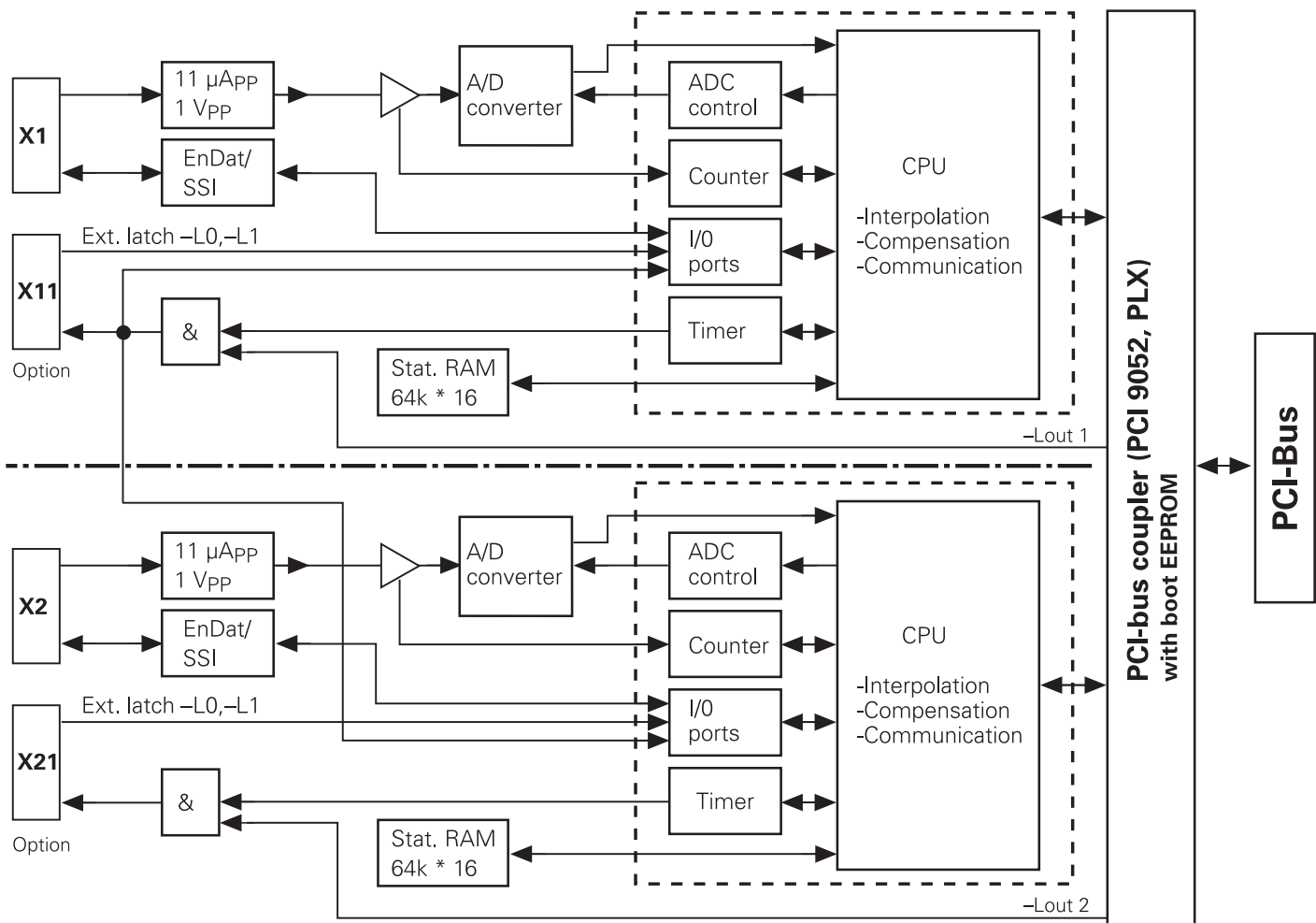

Specifications

IK 220					
Encoder inputs	Two D-sub connections (15-pin), male (X1 and X2) for two encoders				
Input signals (switchable)	<table border="1" style="width: 100%; border-collapse: collapse;"> <tr> <td style="text-align: center;">\sim 1 V_{PP}</td> <td style="text-align: center;">\sim 11 μA_{PP}</td> <td style="text-align: center;">EnDat 2.1</td> <td style="text-align: center;">SSI</td> </tr> </table>	\sim 1 V _{PP}	\sim 11 μ A _{PP}	EnDat 2.1	SSI
\sim 1 V _{PP}	\sim 11 μ A _{PP}	EnDat 2.1	SSI		
Input frequency (max.)	500 kHz 33 kHz –				
Cable length (max.)	60 m 10 m				
Adjustment of encoder signals	Offset, phase and amplitude are adjusted through software				
Signal subdivision	4096-fold				
Data register for measured values	48 bits; only 44 bits are used for the measured value				
Internal memory	For 8192 position values				
Measured value latching	Alternatively through <ul style="list-style-type: none"> • External latch signals (over separate IK assembly for external inputs/outputs) • Software command • Timer • Traversing the reference marks 				
Cycle time of firmware	Max. 25 μ s				
Access time to measured values	<table border="1" style="width: 100%; border-collapse: collapse;"> <tr> <td style="width: 70%;"> <ul style="list-style-type: none"> • Max. 100 μs (without adjustment, without compensation run) • Max. 110 μs (with adjustment, without compensation run) • Max. 160 μs (with adjustment, with compensation run) </td> <td style="width: 30%; text-align: center; vertical-align: top;">Depends on encoder</td> </tr> </table>	<ul style="list-style-type: none"> • Max. 100 μs (without adjustment, without compensation run) • Max. 110 μs (with adjustment, without compensation run) • Max. 160 μs (with adjustment, with compensation run) 	Depends on encoder		
<ul style="list-style-type: none"> • Max. 100 μs (without adjustment, without compensation run) • Max. 110 μs (with adjustment, without compensation run) • Max. 160 μs (with adjustment, with compensation run) 	Depends on encoder				
Interface	PCI bus (plug and play) Local Bus Specification Rev. 2.1				
Driver software and demonstration program	For Windows 98/NT/2000/XP in VISUAL C++, VISUAL BASIC and BORLAND DELPHI				
Encoder outputs	\sim 11 μ A _{PP} Over PCB connector in the IK (10-pin, female) Fitting cable assembly with PC-slot cover available as option				
Power consumption	Approx. 4 W, without encoders				
Dimensions	Approx. 190 mm x 100 mm				
Operating temperature Storage temperature	0 °C to 55 °C (32 °F to 131 °F) –30 °C to 70 °C (–22 °F to 158 °F)				

Electrical Connection

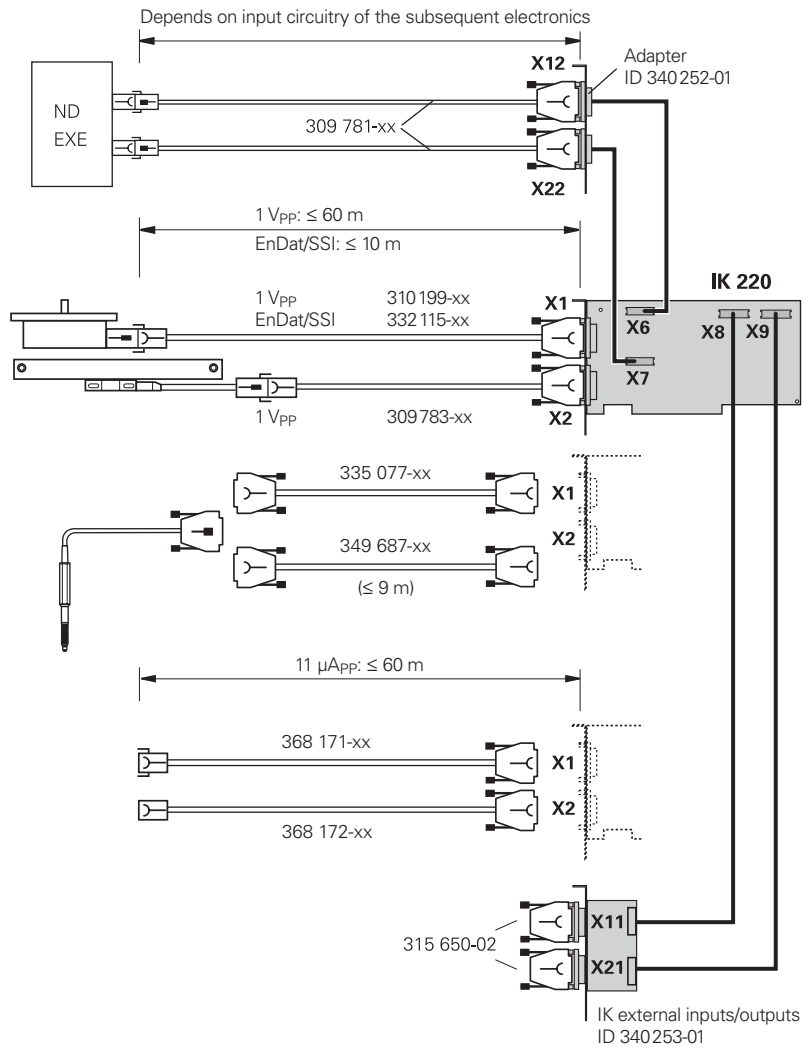

Pin Layout

Symbol	Power supply					Incremental signals						Absolute position values			
	1	9	2	11	13	3	4	6	7	10	12	5	8	14	15
11 μ_{App}	U _p 5 V	Sensor 5 V	U _N 0 V	Sensor 0 V	Inside shield	I ₁ +	I ₁ -	I ₂ +	I ₂ -	I ₀ +	I ₀ -	DNU	DNU	DNU	DNU
1 V_{pp}						A+	A-	B+	B-	R+	R-	DNU	DNU	DNU	DNU
EnDat						A+	A-	B+	B-	R+	R-	DATA	DATA	CLOCK	CLOCK
SSI						DNU	DNU	DNU	DNU	DNU	DNU	DATA	DATA	CLOCK	CLOCK
	Brown/ Green	Blue	White/ Green	White	/	Green/ Black	Yellow/ Black	Blue/ Black	Red/ Black	Red	Black	Gray	Pink	Violet	Yellow

Shield on connector housing

DNU: Do not use this pin

HEIDENHAIN

DR. JOHANNES HEIDENHAIN GmbH

Dr.-Johannes-Heidenhain-Straße 5

83301 Traunreut, Germany

☎ +49 (8669) 31-0

☎ +49 (8669) 50 61

E-Mail: info@heidenhain.de

www.heidenhain.de

